

# MANHATTAN 600H x 480W

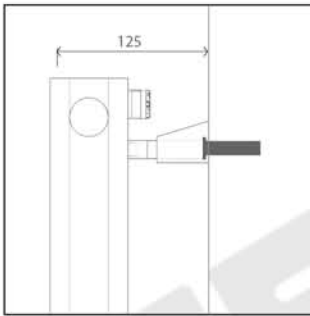

**Projection:** 115mm (max)

**Fixtures:** 4 x Matching Brackets

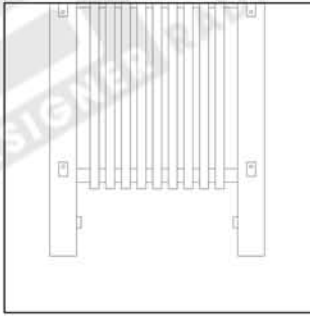
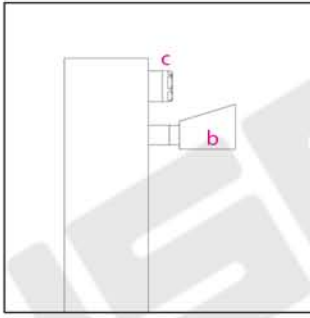
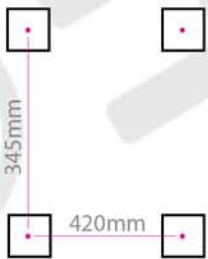

**Outer Finish:** Brushed Stainless Steel

**Base Material:** Stainless Steel

**Bar Pattern:** 9 + 2 Outer Columns

**Pipe Centres:** 339mm

**Output BTUS (delta t50):** 3863

**Output Watts (delta t50):** 1132

**Guarantee:** 5 Years

**Available in Other Sizes:** No

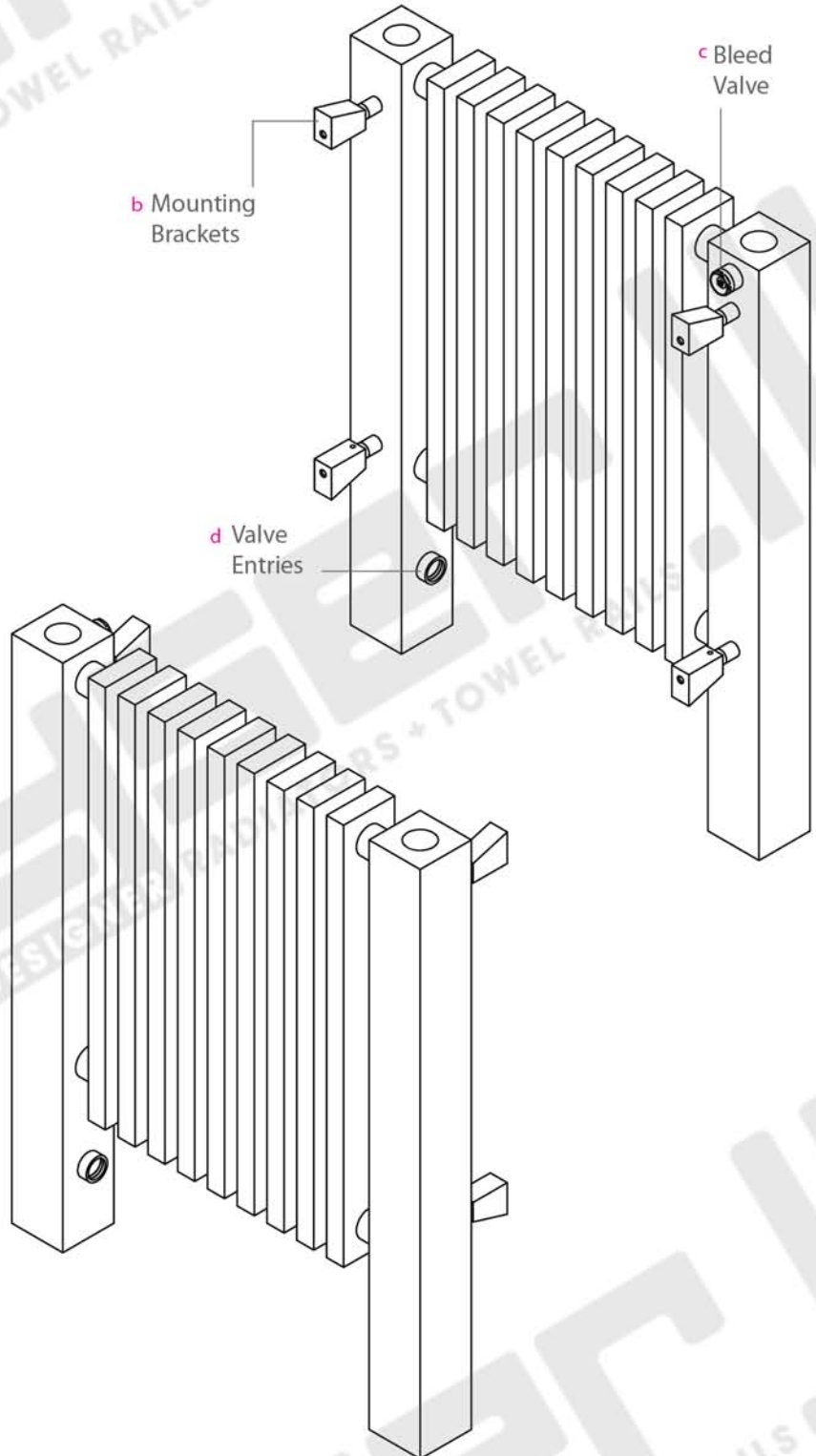

# MANHATTAN 600H x 480W

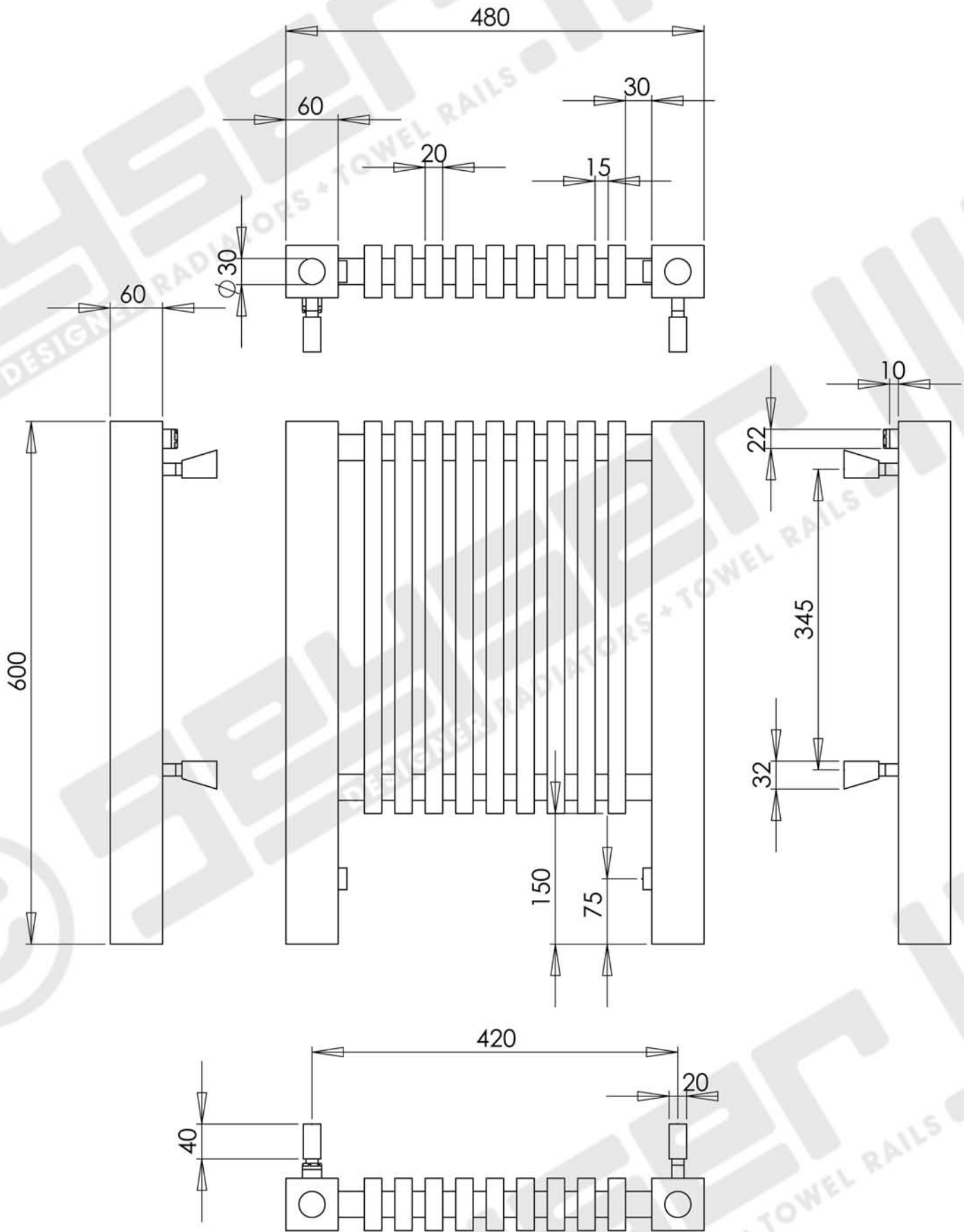

Measurements: mm